

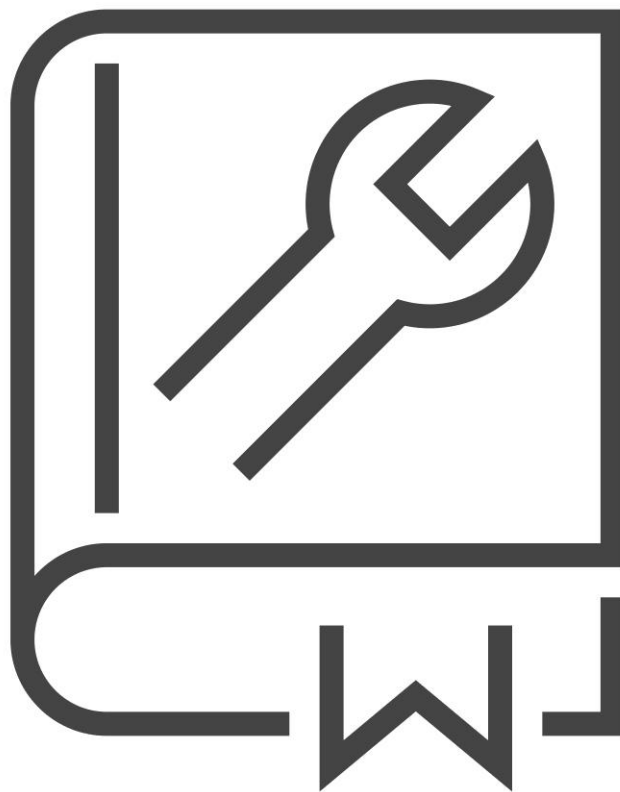

*We are aluminium*

# Manual Raise & Lower Tool



## Introduction

The purpose of this manual is to provide instructions so that traffic signal installers and service operatives can competently use the Hydro Raise and Lowering Tool (to operate the Hydro Low Hinged Traffic Signal Pole) and can maintain the tool.

Traffic signal installers and service operatives must have the required competencies, knowledge and experience to safely work on traffic signal equipment and operate mechanical tooling prior to deployment of the tool.

A site-specific risk assessment must be completed to determine the safest method of raising or lowering the column.

If the positioning and weight of the equipment mounted on the column is within the permitted safe working load, the column may be raised and/or lowered manually. If the load is greater than the permitted load, or there is any doubt about the load, the tool **MUST NOT** be used to operate the column.



### **ATTENTION:**

- Read this manual before using the tool
- Always follow the instructions in this manual.
- Always wear personal protection equipment; helmet, boots, gloves and safety glasses
- Never operate the column in high wind speeds
- Always check the joints and fixations of the tool before lowering the column
- During operation it is advised **NOT TO STAND** in the area underneath the hinged part of the column
- The stainless cable of the winch must not be allowed to come into contact with any sharp objects
- When the winch is operated there must be a corresponding visual motion of the arm. If there is not, stop turning and take measures to control movement of the column  
If visual damage to the cable is detected, raise the column carefully and contact Hydro
- At first installation and during each maintenance, check that the 4x (3x for D145mm column) internal captive M12 bolts are torque to **50Nm**.

### Disclaimer

Despite the careful development and compilation of this manual, it is possible that incorrect or incomplete information is included. Hydro is not liable for any damage, directly or indirectly, related to the use of the information in this manual.

**Product description**

The Hydro Raise and Lowering Tool consists of:

- A. Winch and Bracket
- 1. Clamp
- 2. Clamp with bracket
- 3. Winch

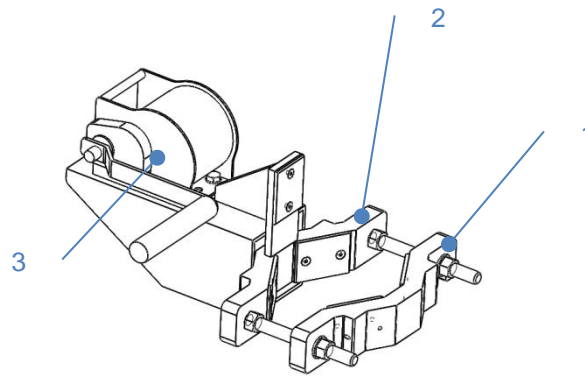

- B. Bracket Arm Complete
- 4. Clamp
- 5. Bracket arm
- 6. Studs
- 7. Fixing point

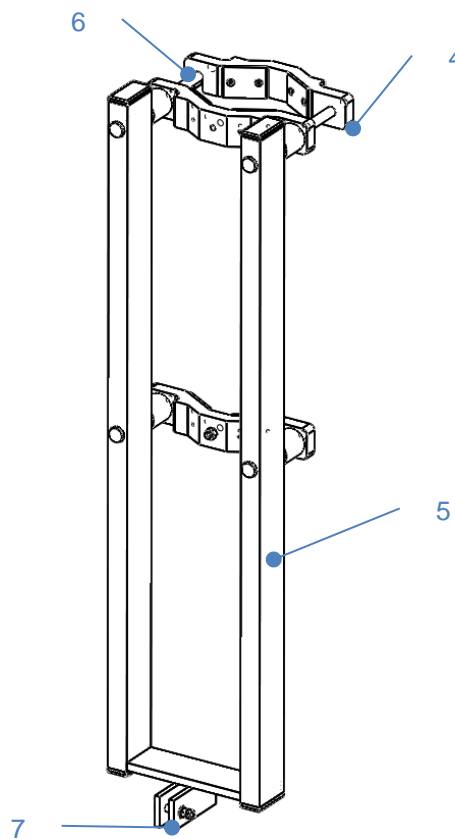

The maximum overturning moment for the Raise and Lowering Tool at tilting point is **182 kgm**.

**Note:** The generated combined load as result of the configuration of the column and mounted loads must not exceed this value!

For assistance or more detailed information, please contact Hydro - Pole Products.

Reference Matrix as guideline for use of tool in combination with Traffic Signal Poles with maximum configurations of head positions.

Reference		114 – 145 R&L	114 – 145 R&L	165-145 R&L	165-145 R&L
Length of post	m	4,1	4,1	6,1	6,1
Height above ground "h"	mm	3650	3650	5420	5420
Insertion length	mm	450	450	680	680
Max. no. of signal heads per position (see calc.-criteria below)	LOW	--	--	2	2
	HIGH	4	4	1	1
Hinged direction	°	90	270	90	270
Article numbers:					
RAL 7037		28015037010002	28015037010003	28015054910001	28015054920001
RAL 9005		28015037010004	28015037010005	28015054910002	28015054920002

For more specific information on dimensions, strength and mechanical properties of the different types of Traffic Signal Poles, please contact us.

**Use of the Raise and Lowering Tool**

Mounting the tool onto the column

Before each use make a complete visual check of all parts including the welds for damage, wear and fracturing.

1. Unlock both door locks with the door key.  
Take the door out of the column.



2. Mount the winch bracket including clamp onto the parallel part of the column as shown.  
Tighten the two M16 bolts. As a visual guide, mount the winch bracket in line with the center of the wedge.

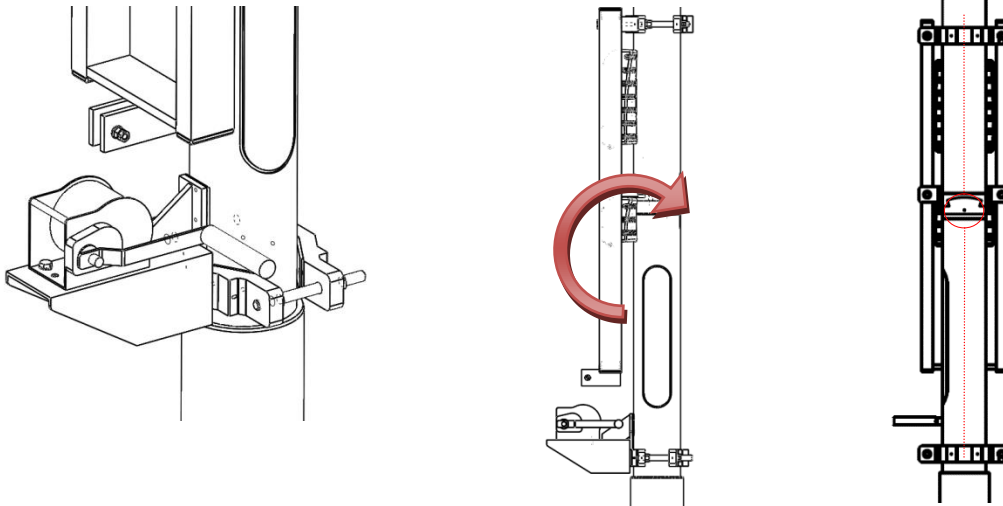

**Notes:**

- If the column is wet, it is advised to wipe it dry where the tool is to be attached.
- Make sure that the winch is positioned as shown, rotated 180 degrees with respect to the lowering direction of the column.

3. Mount the bracket arm in line with the winch bracket. Make sure that there is enough space between 3. Winch and 7. Fixing point.

Mount the lowest support approximately above the hinge mechanism split or other objects like nearside signals or demand units. This to make sure, that the wedge is clear for operation.

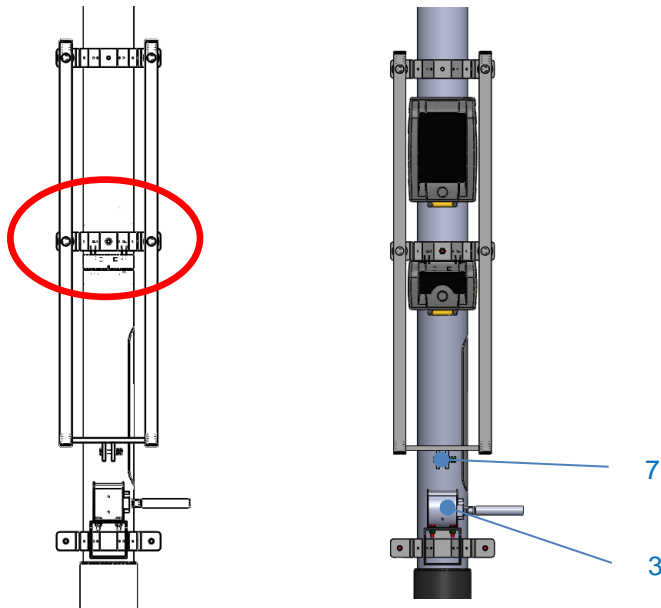

4. Slide the 4. Clamp over the studs
5. Tighten the two M16 bolts

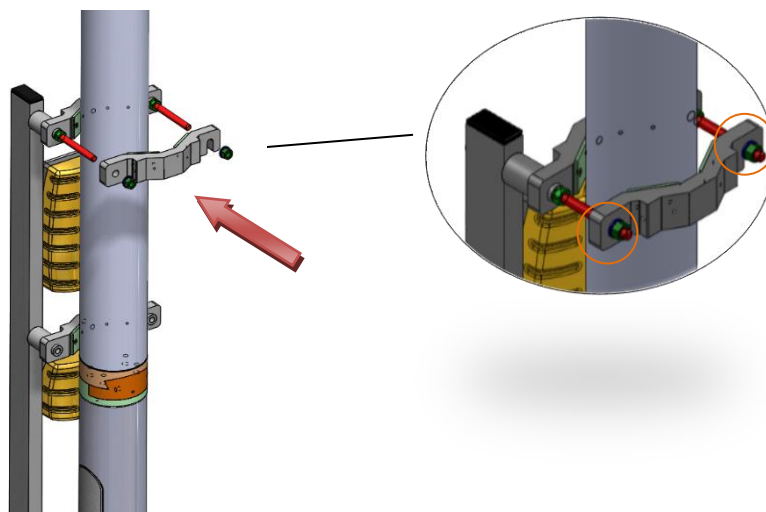

- Fasten the 3. Winch cable onto the 7.fastening point.

**Note:** Check all connections are secured and make sure that the cable is secured. Ensure the cable is tightened prior to loosening captive bolts. This to check if all is secured!

Then move on to the “lowering and raising of the hinged column”, *Section 7*.



- Use the ratchet wrench and extension bar to undo the captive bolts that secure the “wedge” in place. **UNDO THESE BOLTS ONLY.** Leave the bolt(s) securing the hinge in place. There are two bolt configurations, depending on the diameter of the pole; 145mm diameter poles have three bolts in total; 165mm diameter poles have four bolts in total:

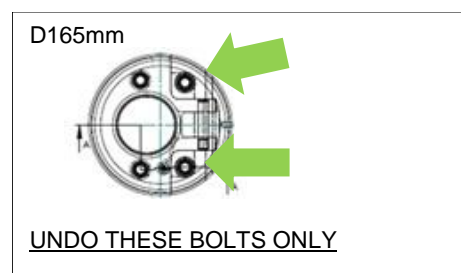
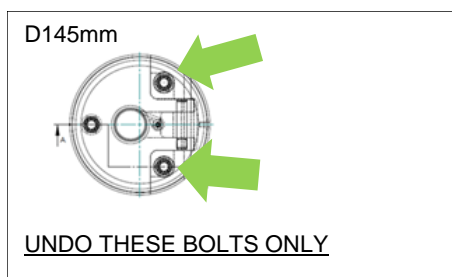

- Screw the M6 eye bolt into the hole on the outside of the wedge. Place your other hand ‘high’ onto the column and pull out the wedge.

**Note:** If the wedge sticks, free it by pushing against the top section of the column while simultaneously pulling the wedge.



9. Check to ensure the hinge pin is in place.

- If the hinge pin is in place (see detail 2 in figure 1), then replace the wedge! When the wedge is in place, then you can undo the remaining internal captive M12 hexagon (10mm) socket head cap screws, with a ratchet, hexagon key or other appropriate tool (H12 Hex Sockets or H12 Hex Drive Socket).
- If the hinge pin is missing, replace the wedge, tighten all captive bolts to 50Nm, replace the door, remove the demountable tool and record the details from the CE label above the door. Report incident of missing hinge pin directly to the supplier.

**Note:** The M12 bolts in the column are captive to prevent complete removal.

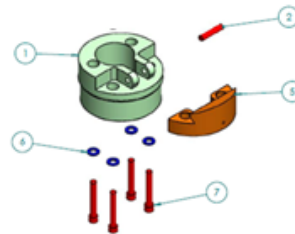
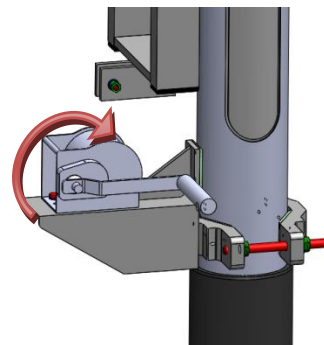

Figure 1



10. Lower the column by rotating the handle until it is completely lowered.

**CAUTION:** By performing step 8 - 10 the column is supported only by the winch and is ready to be lowered! Stand clear of the area where the hinged top section of the column could come down.



11 Once the work is completed, Steps 1 to 10 should be carried out in reverse order. Make sure that the 4x (3x for D145mm column) internal captive M12 bolts are torqued to **50Nm**.

**Pole Products**

Hydro Extrusion Drunen BV  
P.O. Box 75  
5150 AB Drunen  
The Netherlands

**Visiting address:**  
Alcoalaan 12  
5151 RW Drunen  
The Netherlands

[www.hydro.com/poleproducts](http://www.hydro.com/poleproducts)  
E: [info.poleproducts.nl@hydro.com](mailto:info.poleproducts.nl@hydro.com)  
T: +31 416 386 200

**Registration No.**  
No. 17205924