

# Aluminium Brackets



## Brackets extend the illuminated area

Alongside public roads, columns often are situated at some distance from the roadway and it is therefore necessary to place the luminaire at a distance from the column, i.e. over the roadway. For this, the range of Hydro brackets includes single and double brackets, fixed on the column or detachable.

Demountable brackets have the advantage that they achieve the optimum solution in terms of strength. In addition, they offer advantages in the field of logistics and installation of the column. Use can be made of aluminum cast and connection pieces in both single and double versions.

Besides standard brackets, Hydro also produce custom made brackets in all shapes and dimensions.

Local technical support available in the UK.

## In compliance with standards and regulations:

- Design in accordance with the British standard BS-EN 40-6
- Calculations according to the British standard BS-EN 40-3-3
- Passively safe according to BS-EN 12767 – see certificate EN 40
- *Cradle to Cradle Certified™* silver

## Assembly:

- Fixed
- Cast piece
- Invisible joint

## Brackets

### Fixed brackets

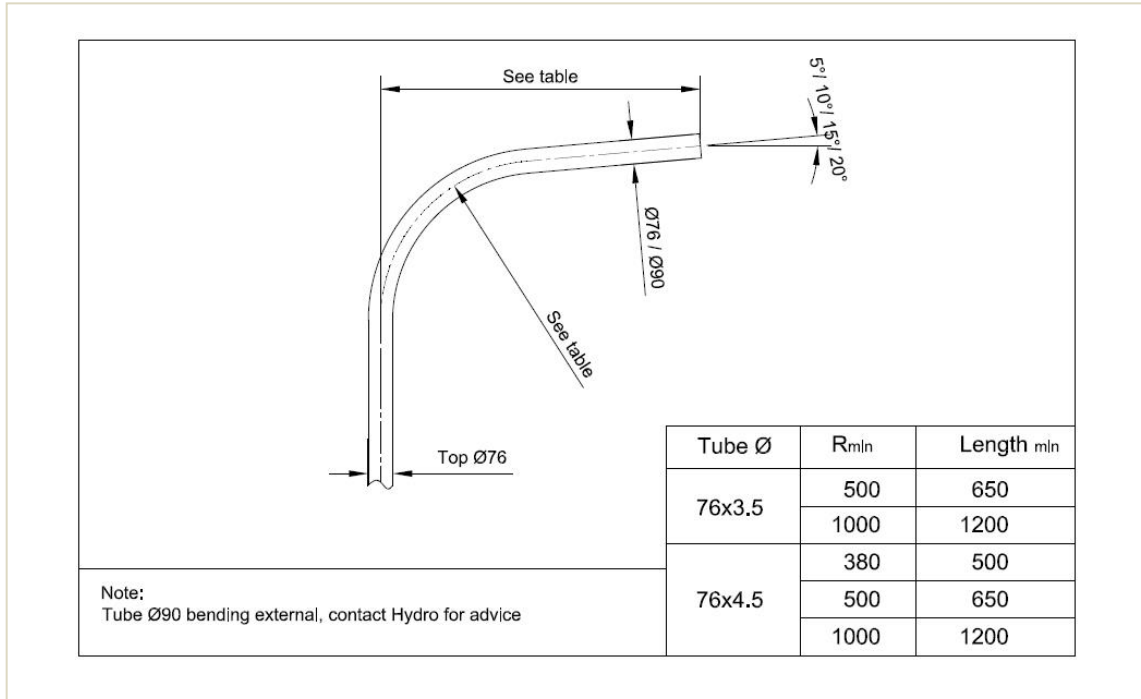

### Brackets with invisible joint

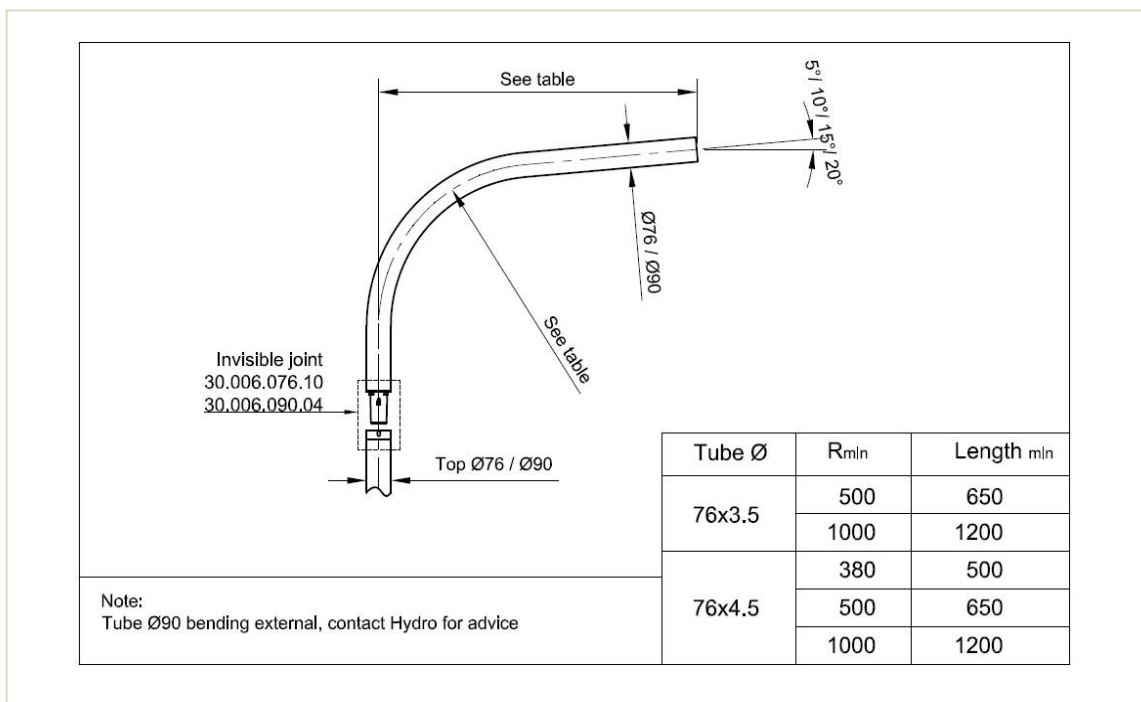

## Brackets

### Brackets with cast piece

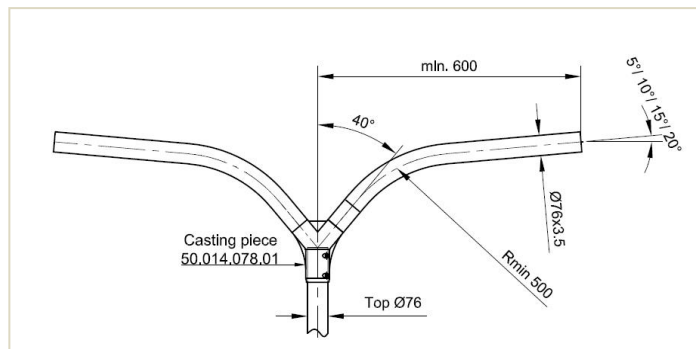
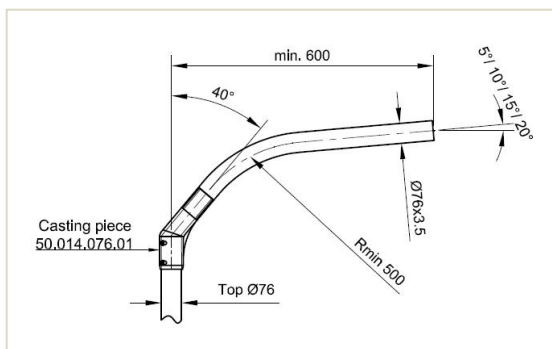
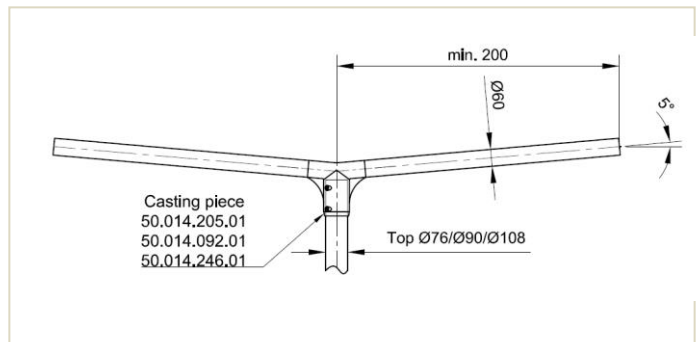
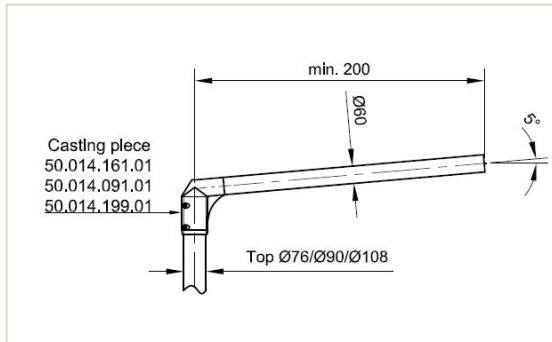

### Technical characteristics:

- Seamless tube made of aluminium extrusion;
- Alloy EN AW6060 T66;
- 100% recyclable;
- Surface standard satin brushed finish. Option anodized or electrostatically powder coated versions (in an optional RAL color). The bracket will then be supplied in a detachable version.

Hydro is not liable for incomplete or incorrect information provided on this product sheet.